

SPC No.	Version	Issue Date	Approval	Making
230420001	B	2023-4-19	Mr Chiang	Ms Lee

GESMD5050RGB

Datasheet



Features :

- High Luminous Intensity
- Based on Blue/Green : InGaN, Red : AlGaInP technology
- Wide viewing angle : 120°
- Excellent performance and visibility
- Suitable for all SMT assembly methods
- IR reflow process compatible
- Environmental friendly; RoHS compliance

Typical Applications :

- Signal and Symbol Luminaire
- Indoor and Outdoor Displays
- Backlighting (illuminated advertising, general lighting)
- Interior Automotive Lighting

Absolute Maximum Ratings

Absolute maximum ratings (T_a=25°C)

Parameter	Symbol	Value	Units
DC Forward Current	(R)	20	mA
	(G/B)	20	
Pulse Forward Current (tp≤100μs, Duty cycle=0.25)	I _{pulse}	25	mA
		30	
Reverse Voltage	V _R	5	V
LED Junction Temperature	T _J	115	°C
Operating Temperature	-	-40 ~ +85	°C
Storage Temperature	-	-40 ~ +125	°C
ESD Sensitivity (HBM)	V _B	2,000	V
Soldering Temperature	T _s	Reflow Soldering : 255~260°C/10~30sec Manual Soldering : 350°C/3sec	

Notes:

- The values are based on 1-die performance.
- * I_{fp} condition: pulse width ≤0.1msec and duty ≤1/10.

Electronic optical Parameters

Model Number: GESMD5050RGB at 25°C

Parameter	Condition	Symbol	Color/CCT	Min	Typical	Max	Unit
Wavelength	IF=20mA	Wd (λ)	R	620	-	625	nm
			G	520	-	525	
			B	465	-	470	
Forward Voltage	IF=20mA	VF	R	1.8	2.0	2.2	V
			G	2.8	3.0	3.2	
			B	2.8	3.0	3.2	
Luminous Flux	IF=20mA	IV	R	600	-	900	MCD
			G	1500	-	2000	
			B	400	-	600	
Beam Angle	IF=20mA	2θ 1/2	-	-	120°	-	-
Reverse Current	IF=20mA	IR	-	-	-	10	μA

Note: Luminous flux performance is guaranteed within published operation condition, GREELED maintains a tolerance of ±10%

Mechanical Dimensions

Emitter Type Dimension

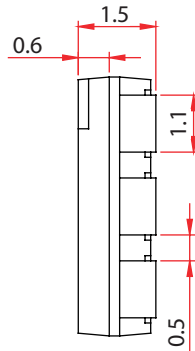
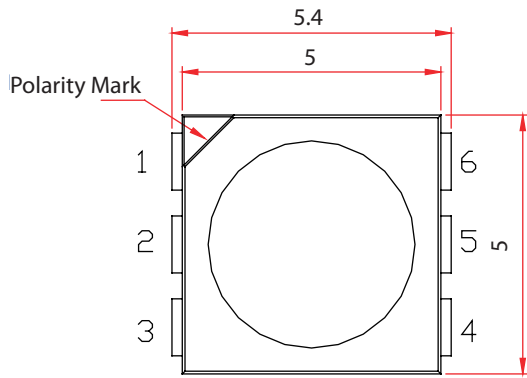

Unit: mm
Tolerance: ± 0.2 mm

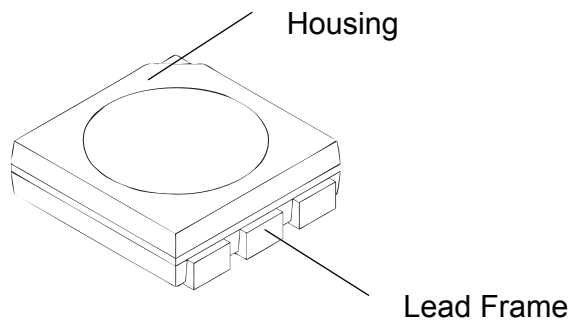
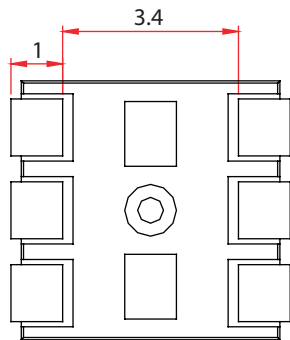

Circuit

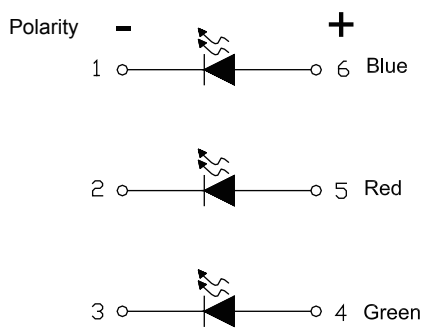

Solder Pad

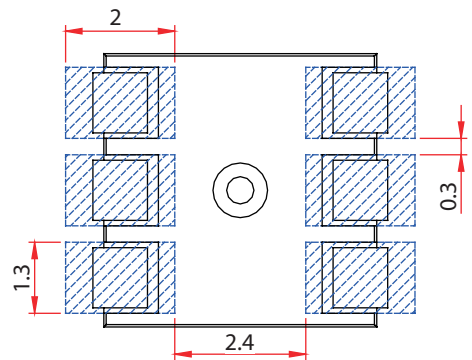

- Notes:
1. All dimensions are measured in mm.
 2. Tolerance : ± 0.2 mm

Characteristic Curve

Color Spectrum

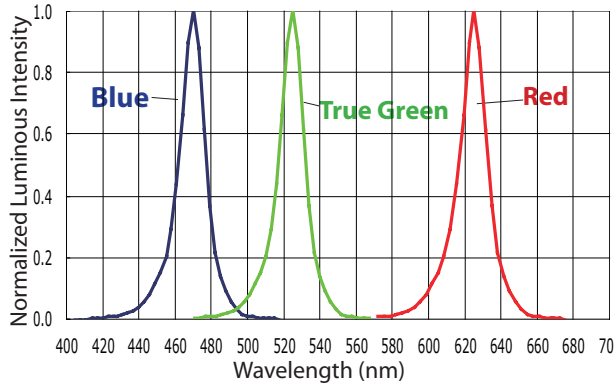

Color Spectrum for PLCC 5050 series

Radiation Diagram

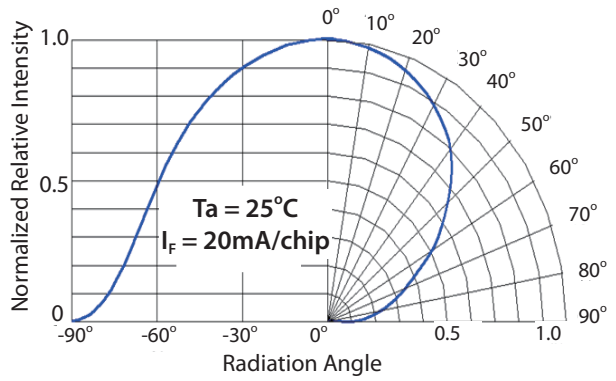

Beam pattern diagram for PLCC 5050 series

Luminous Flux vs. Forward Current

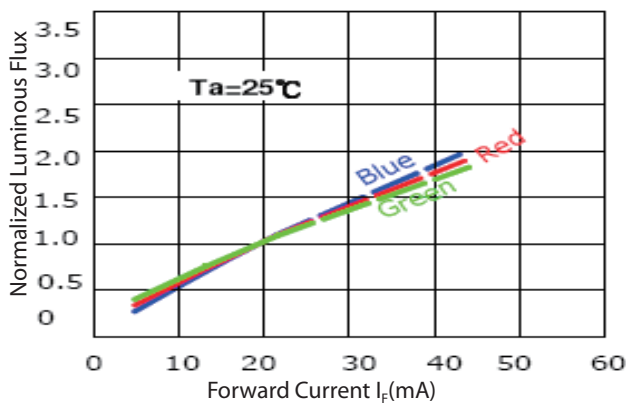

Forward current vs. luminous flux at $T_a = 25^\circ\text{C}$ for PLCC 5050 series

Forward Voltage vs. Forward Current

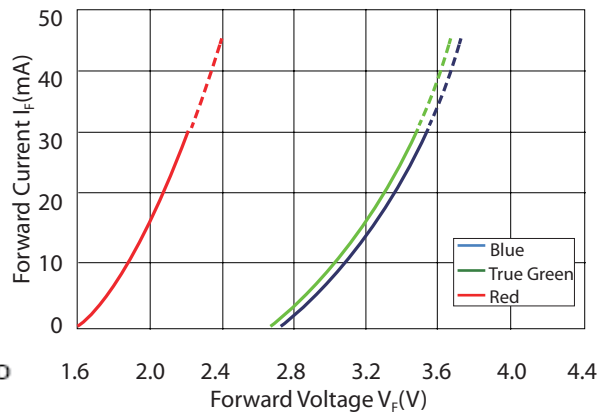

Forward current vs. forward voltage for PLCC 5050 series

Luminous Flux vs. Junction Temperature

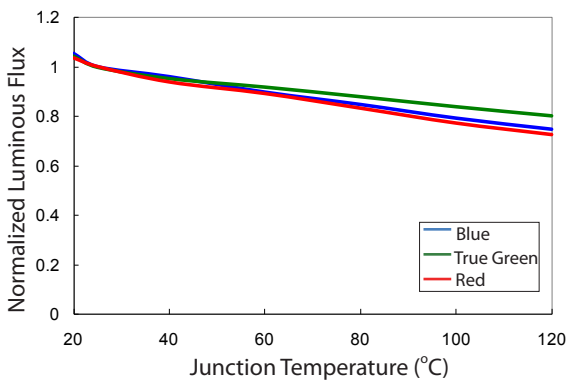

Luminous Intensity vs. Forward Current for PLCC 5050

Wavelength vs. Junction temperature

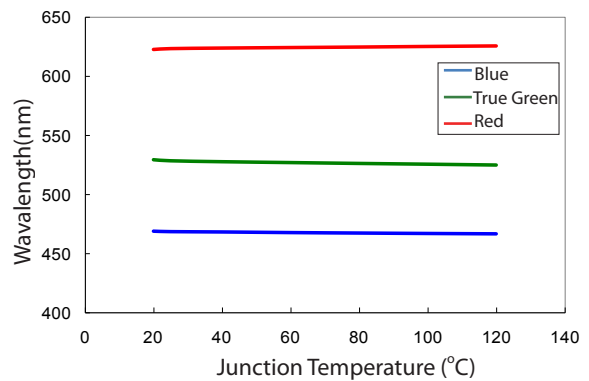

Wavelength vs. Junction Temperature($^\circ\text{C}$) for PLCC 5050

Forward Voltage vs. Junction temperature

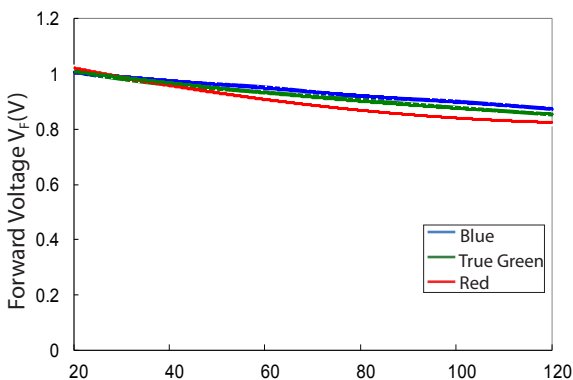

Wavelength vs. Forward Current

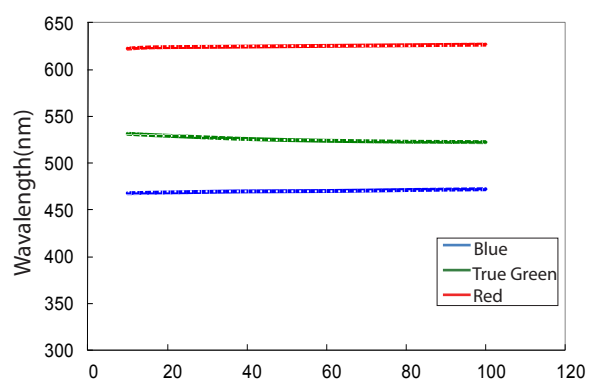

Reflow Profile

The following reflow profile is from IPC/JEDEC J-STD-020D which provided here for reference.

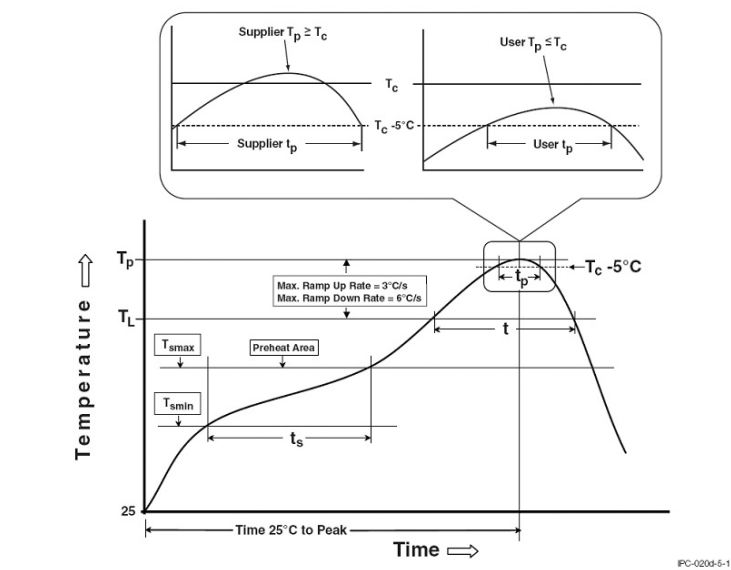

Reflow Profiles

Classification Reflow Profiles

Profile Feature	Pb-Free Assembly
Preheat & Soak	150 °C
Temperature min (T _{smin})	200 °C
Temperature max (T _{smax})	60-120 seconds
Time (T _{smin} to T _{smax}) (t _s)	
Average ramp-up rate (T _{smax} to T _p)	3 °C/second max.
Liquidous temperature (T _L)	217 °C
Time at liquidous (t _L)	60-150 seconds
Peak package body temperature (T _p)*	255 °C ~260 °C *
Classification temperature (T _C)	260 °C
Time (t _p)** within 5 °C of the specified classification temperature (T _C)	30** seconds
Average ramp-down rate (T _p to T _{smax})	6°C/second max.
Time 25°C to peak temperature	8 minutes max.

Notes:

- * Tolerance for peak profile temperature (T_p) is defined as a supplier minimum and a user maximum.
- ** Tolerance for time at peak profile temperature (t_p) is defined as a supplier minimum and a user maximum.

Reliability

NO .	Test Item	Test Condition	Remark
1	Temperature Cycle	-40°C~100°C 30, 30, mins	100 Cycle
2	Thermal Shock	-40°C~100°C 15, 15 mins ≤ 10 sec	100 Cycle
3	Resistance to Soldering Heat	T _{SOL} =260°C, 30 sec	3 times
4	Moisture Resistance	25°C~65°C 90% RH 24 hrs / 1 cycle	10 Cycle
5	High-Temperature Storage	T _A =100°C	1,000 hrs
6	Humidity Heat Storage	T _A =85°C RH=85%	1,000 hrs
7	Low-Temperature Storage	T _A =-40°C	1,000 hrs
8	Operation Life test	25°C	1,000 hrs
9	High Temperature Operation Life test	85°C	1,000 hrs
10	High Humidity Heat Life Test	85°C, 85%RH	1,000 hrs
11	ON/OFF Test	30 sec ON, 30 sec OFF	1.5W times

Failure Criteria

Item	Criteria for Judgment	
	Min.	Max.
Lumen Maintenance	85%	-
$\Delta u'v'$	-	0.006
Forward Voltage	-	Initial Data x 1.1
Reverse Current	-	10 μ A
Resistance to Soldering Heat	No dead lamps or visual damage	

Product Packaging Information

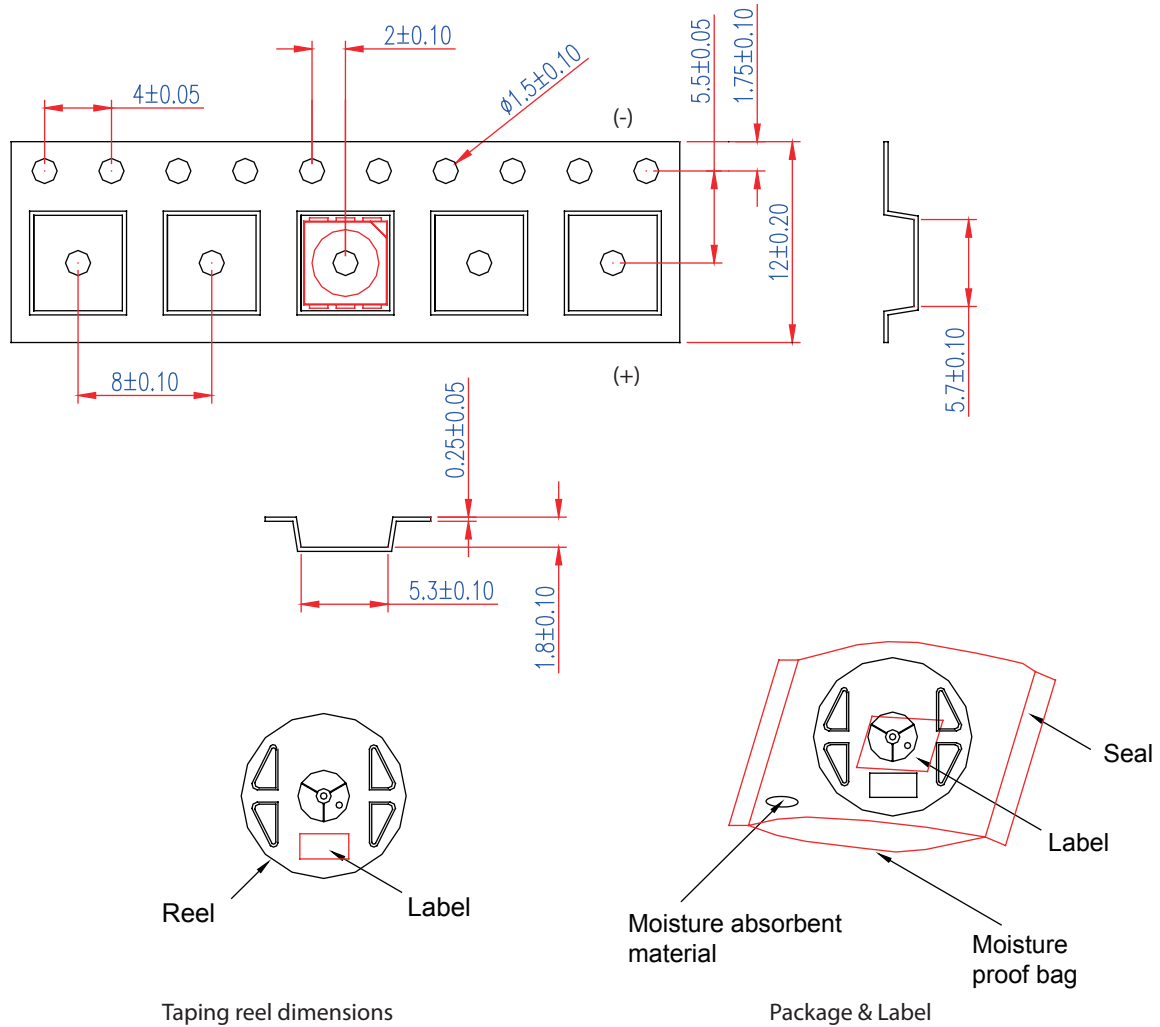

Model	Package	Emitting Color	QTY/Reel	Reel/CTN
GESMD5050RGB	SMD5050	RGB	1k/Reel	50Reel/CTN

GREELED ELECTRONIC LTD

www.gree-leds.com

Add: 2F,1st Building logistic park,shiyang town,shenzhen city

E-mail:sales@gree-leds.com Skype:greeledelectronic