

Specification

Model No.: GE8808B-3535
 Product: 12V 0.15W Pixel led
 Document No.: SPC-TOP-C/230020
 Issue Date :18-04-2023
 Version: A-23

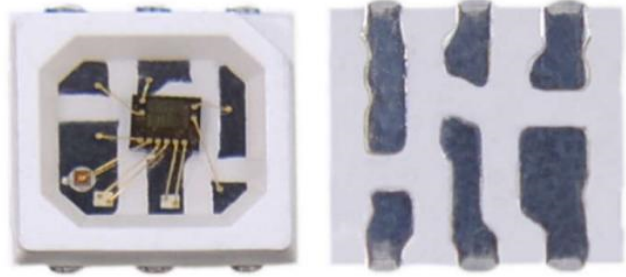

Greeled Approval		Customer Approval	
Audit	Confirmation	Approval	Audit
Mr Chiang	Ms Lee		
Date:		<input type="checkbox"/> Qualified	<input type="checkbox"/> Disqualified
Reason:			

1.Product feature:

- The control circuit and RGB chips are integrated in one SMD3535 package as one pixel,Built in various of function units.
- Adopt led chips in series design,Default current 9mA,Improve energy efficiency.
- 12V single pixel addressable,Improve Voltage-drop Issue.
- It have backup data to prevent signal interrupt.(Break-Point resume function)
- The PWM Scanning Frequency 8khz
- Each color 8Bits,256 Gray scale, $256*256*256=16777216$ true color display.
- Data transmission rate up to 800kbps
- The pixel cascades number is not less than 1024 pixels at 30 frame per second.
- The data transmit base on SPI Communication protocol

2.Working principle description:

The GE8808B-3535 led adopt single data signal communication method, The data encoding adopt RZ code. The Din of led receive data from signal source,locking 24bit data and send them to data latch, PWM scanning unit deal 24bit data and send relative duty ratio signal to relative Emitting chips OUTR,OUTG,OUTB.

At the same time, Reshaping and amplify extra data,Forwarding them to subsequent led via Dout of led. Based on this rule. The data reduce 24bit pass through every pixel. All Emitting chips receive relative duty ratio signal and Emitting color.

The data auto-reshaping forwarding technology to ensure that the number of cascaded pixel is not limited. The more cascaded pixels request the higher data transmission rate.

3.Application:

- Billboard,light box,Device,Cabinet decoration
- The Component of light source.

4. Package dimension:

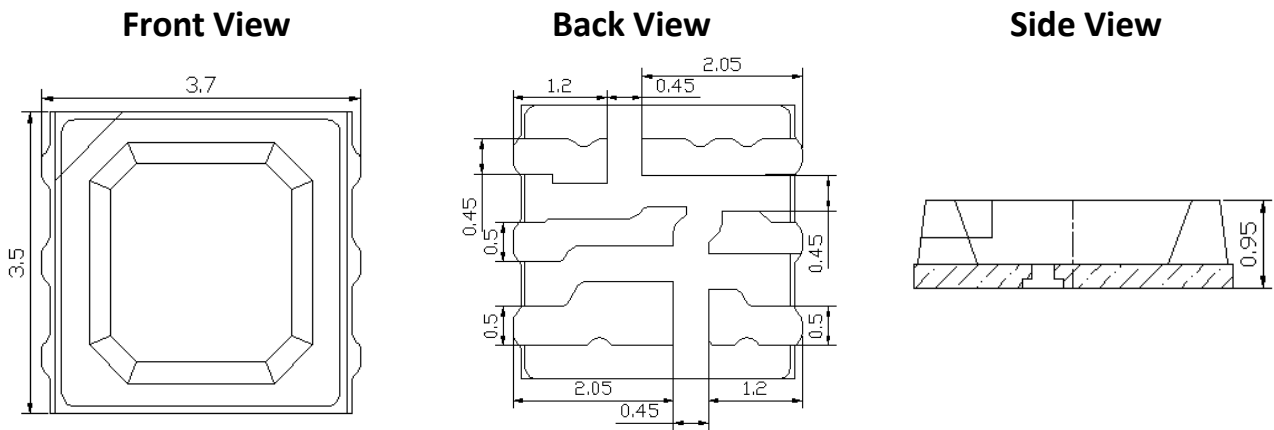

Remarks: All dimensions are marked in millimeters and the tolerance is ± 0.15 mm, unless otherwise specified.

5. Pin diagram and function description:

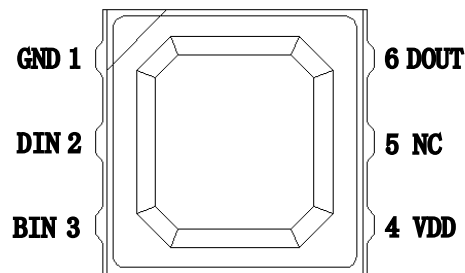

No.	Symbol	Function description
1	GND	Ground
2	DIN	Control data signal input
3	BIN	Backup data
4	VDD	Power supply
5	NC	Empty
6	DOUT	Control data signal forwarding output

6.RGB chip characteristic parameter Ta=25℃ at 9mA:

Color	Wavelength(nm)	Light Intensity (mcd)	Lumen (LM)
Red	620-630	200-400	0.6-1.0
Green	520-535	600-1000	2.0-3.0
Blue	460-475	150-300	0.5-0.8

7.Maximum rating (if no special instructions,Ta=25℃, VSS=0V):

Parameter	Symbol	Range	Unit
Voltage	VDD	-0.4~+15	V
Logic input voltage	VI	-0.5~12.5	V
R/G/B Output current	IOUT	9	mA
Working temperature	Topt	-40~+85	℃
Storage temperature	Tstg	-50~+85	℃
ESD pressure (body mode)	VESD	2000	V

8.Electrical characteristics (if no special instructions, Ta=25℃):

Parameter	Symbol	Min	Typical	Max	Unit
The chip supply Voltage	VDD	10.5	12	13.5	V
R/G/B port output drive current	IOUT	-	9	-	mA
High level input voltage	VIH	4	-	-	V
Low level input voltage	VIL	-	-	1	V
Static power	IDD	-	2	-	mA
PWM Frequency	fPWM	-	8	-	KHZ

9.Switch characteristics (if no special instructions, Ta=25°C):

Parameter	Symbol	Min	Typical	Max	Unit	Test Conditions
Data transfer rate	fDIN	-	800	1100	KHz	-
Transmission delay time	tPLZ			500	ns	
	tPHZ	-	-	500	ns	-

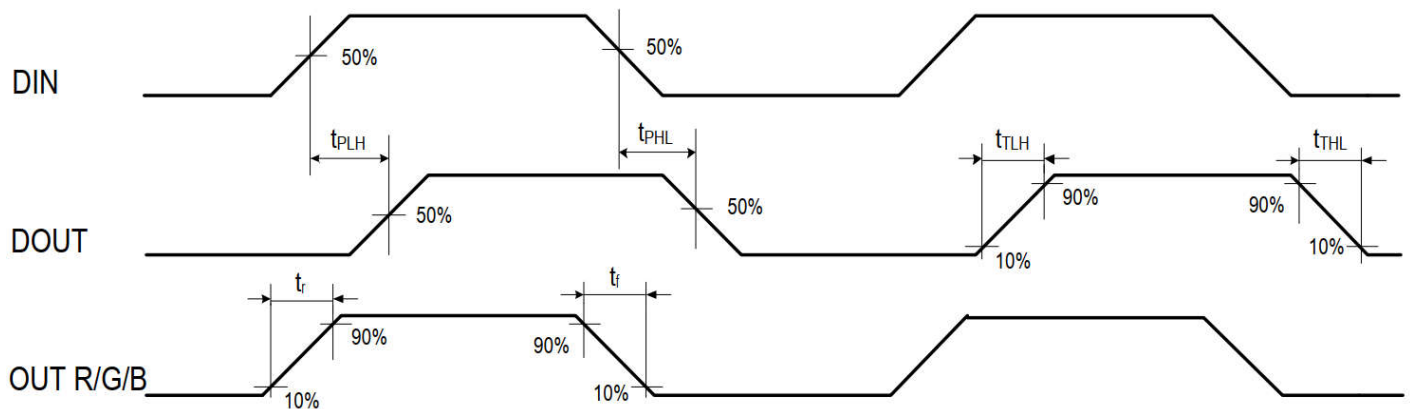

10.Data transmission time (TH+TL≥1.25μs)

Name	Description	Min	Typical	Max	Allowable error	Unit
T0H	0 code, high level time	-	0.3	-	±0.05	US
T1H	1 code, high level time	-	0.9	-	±0.05	US
T0L	0 code, low level time	-	0.9	-	±0.05	US
T1L	1 code, low level time	-	0.3	-	±0.05	US
TRST	Reset code, low level time	80	200	-	-	US

11.Coding timing diagram:

The chip protocol adopt unipolar return-to-zero code, and every symbol must have be converted. Each symbol of this protocol starts with a high level, and the time width of the high level determines the "0" code or the "1" code.

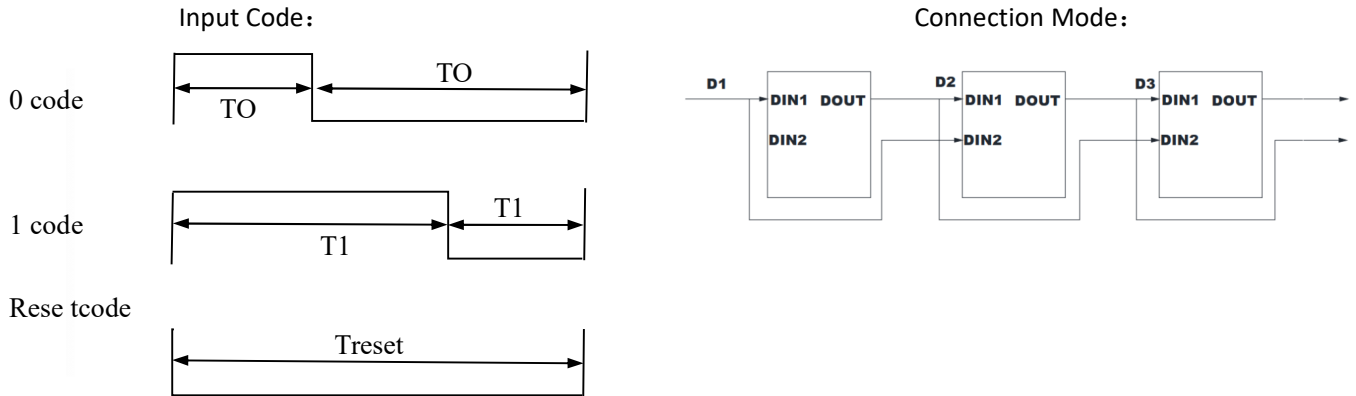

12.Data transmission method (Ta=25°C) :

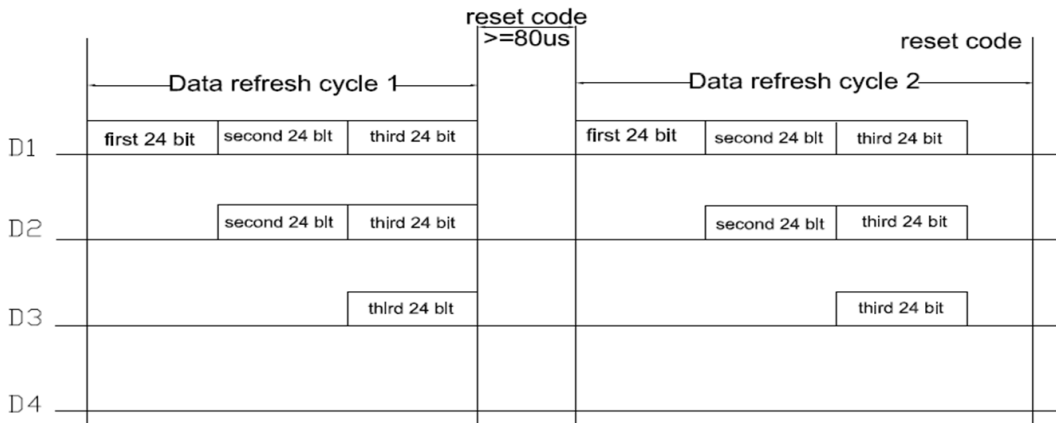

Note: D1 is the data sent by the MCU, and D2, D3, and D4 are the data that the cascade circuit automatically reshapes and forwards.

13.Data structure (Ta=25°C):

R7	R6	R5	R4	R3	R2	R1	R0	G7	G6	G5	G4
G3	G2	G1	G0	B7	B6	B5	B4	B3	B2	B1	B0

Note: The high bit is sent first, and the data is sent in the order of RGB (R7 → R6 →.....B0).

14. Typical application circuit:

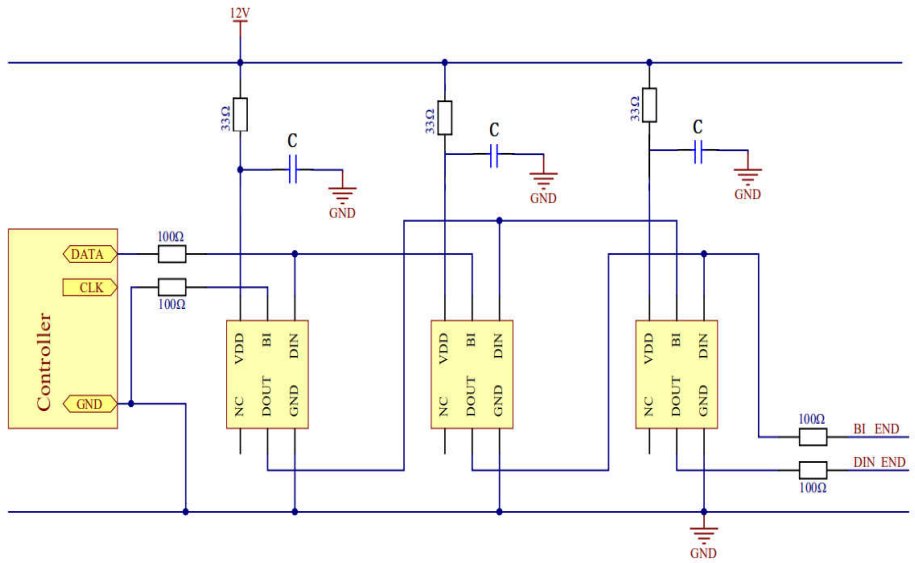

The DIN and BIN input and output terminals of the product need to be connected in series when necessary. The size of the protective resistor R depends on the number of cascaded LEDs. The more the number of cascades, the smaller R. Generally, a value between 75-120 ohms is recommended, The recommended value is 100 ohms, the VDD series resistance is 27-100 ohms, and the recommended value is 51 ohms.

15. Typical optical characteristic curve:

Welding temperature VS Forward current

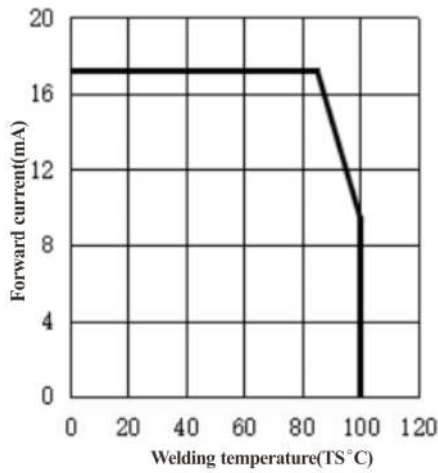

Forward current VS Relative light intensity

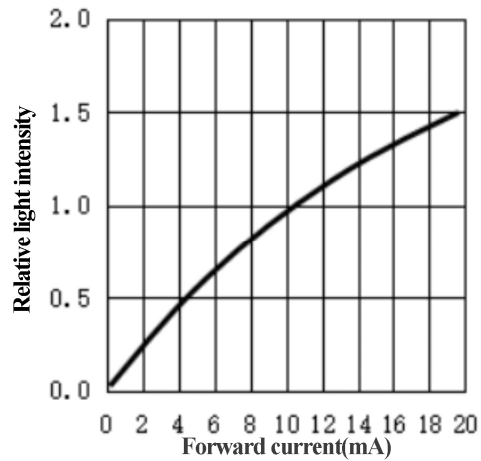

Forward voltage VS Forward current

Ambient temperature VS Rrelative light intensity

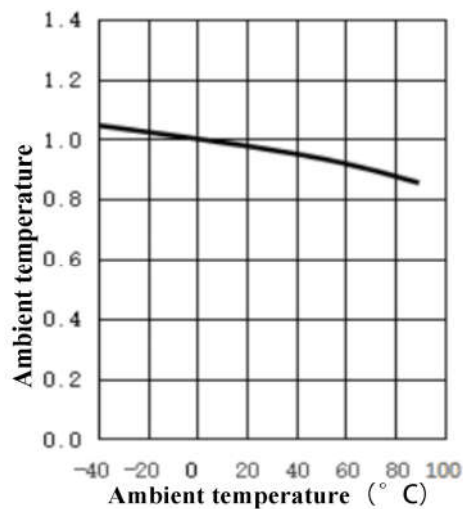
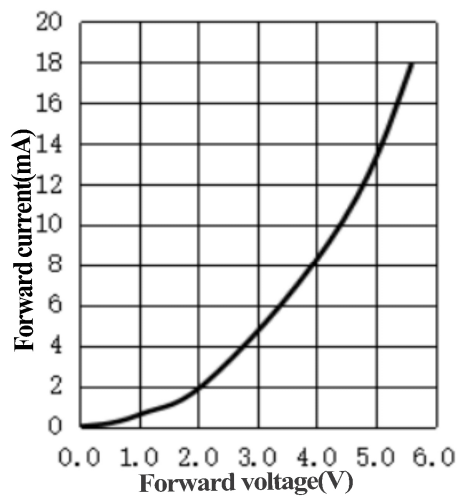

Relative spectral distribution chart

Relative spectral distribution chart

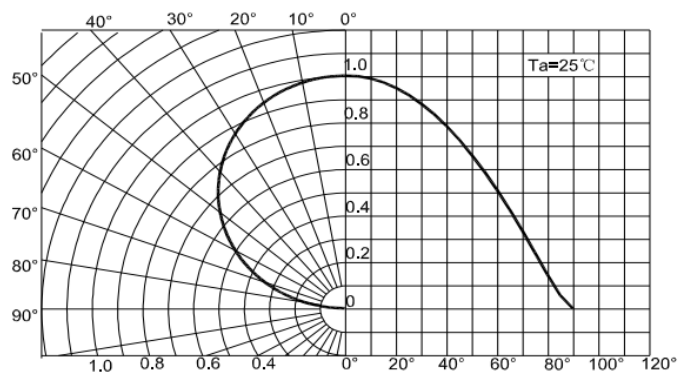
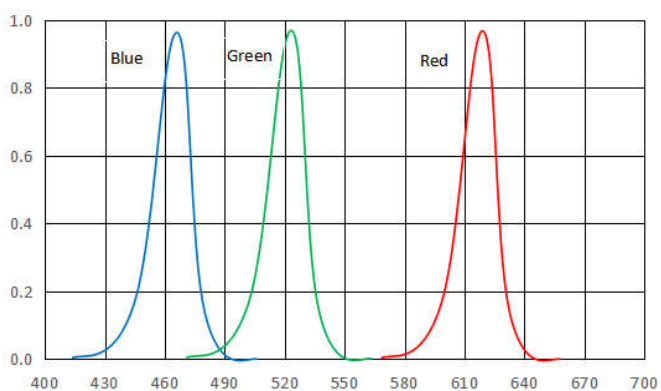

16.Packing specifications:

Reel size:

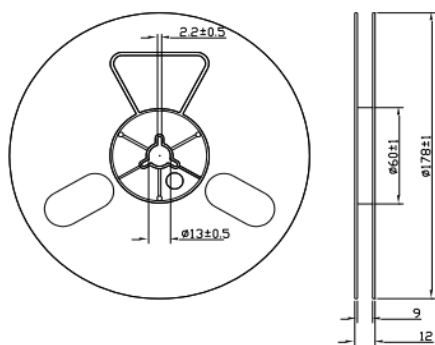

Carrier tape specifications (unit: mm)

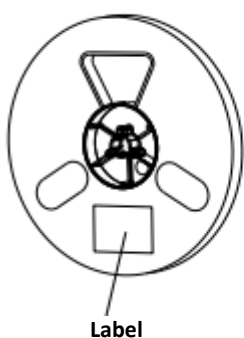
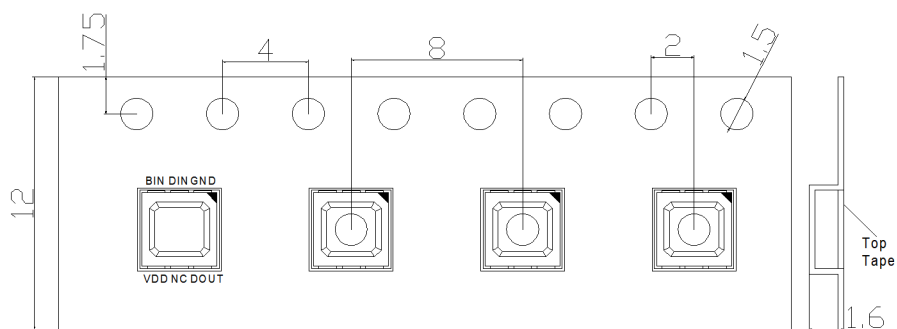

Label

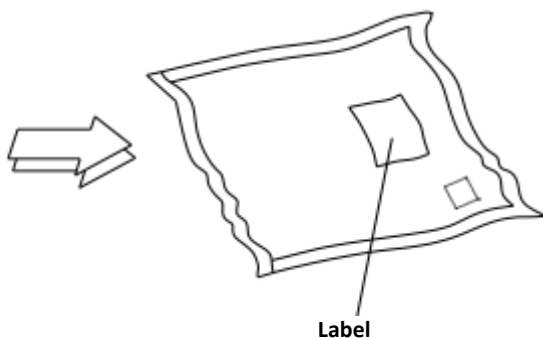

Label

Model	Appearance color	Emitting Color	QTY/Reel	Reel/CTN
GE8808B-3535	White mask	RGB	1.5k/Reel	50Reel/CTN

GREELED ELECTRONIC LTD

Add: 2F,1st Building logistic park,shiyang town,shenzhen city

E-mail:sales@gree-leds.com Skype:greeledelectronic